

Technical Reference Section: pH/ORP

Information in this section addresses frequently asked questions regarding pH & ORP and is provided as REFERENCE ONLY to supplement procedures and recommendations specifically outlined in individual product instruction manuals. All manuals, data sheets, and additional helpful information are available at www.gfsignet.com.

Definition of pH

pH is defined as the negative logarithm of the Hydrogen ion concentration in aqueous solutions. The common pH scale ranges from 0 to 14, with 7 being neutral water (H₂O). At pH 7, Hydrogen ions (H⁺) exist in equal concentration to Hydroxyl ions (OH⁻). A solution is considered to

be acidic if the concentration of H⁺ exceeds that of OH⁻, and is indicated by pH values below 7. Conversely, a solution is considered to be basic if the concentration of H⁺ is less than that of OH⁻, and is indicated by pH values above 7.

Common Acids

1M HCl: 0.0 pH
Sulfuric Acid: 0.3 pH
Lemon Juice: 2.0 pH
Vinegar: 3.0 pH
Wine: 3.5 pH
Beer: 4.5 pH
Milk: 6.0 pH

Common Bases

Egg Whites: 7.5 pH
Seawater: 8.0 pH
Sodium Bicarbonate: 8.4 pH
Ammonia: 11.6 pH
Photo Developer: 12.0 pH
0.1M NaOH: 13.0 pH
Lye: 14.0 pH

pH Scale

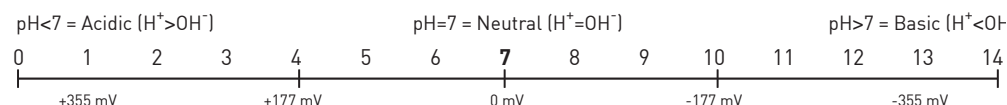

(Theoretical: 59.16 mV/pH @ 25°C)

Definition of ORP

ORP is an abbreviation for **O**xidation-**R**eduction **P**otential. Oxidation is a term used to denote the occurrence of a molecule losing an electron. Reduction occurs as a molecule gains an electron. The "potential" is simply an indication of a solution's propensity to contribute or accept electrons. ORP reactions (sometimes referred to as REDOX) always take place simultaneously. There is never oxidation without reduction, and ORP electrodes are used to detect electrons exchanged by molecules as these reactions occur.

Both pH and ORP electrodes produce voltages that depend on the solutions in contact with their sensing ends. Most pH electrodes, including the Signet brand, are designed to produce 0 mV at pH 7, positive mV below pH 7 (associated with the charge of the Hydrogen ion, H⁺) and negative mV above pH 7 (associated with the charge of the Hydroxyl ion, OH⁻). According to the Nernst Equation, the interval between each pH unit is approximately 59.16 mV at 25°C. This "raw" output is converted to a pH value by the display instrument.

The ORP scale is typically -1000 mV to +1000 mV, and the electrodes produce these values directly.

Whereas pH is a specific measure of the Hydrogen ion concentration in solution, ORP only provides relative measures of chemicals and cannot discriminate one from another. Although non-specific, it is a very useful and inexpensive method of monitoring and controlling the activity of such compounds as chlorine, ozone, bromine, cyanide, chromate, and many other chemical reactions.

It is worth noting that Temperature Compensation, very important for accurate pH measurement, is NOT used in ORP measurements. Temperature does indeed affect the reactionary potential of all chemicals, some to a greater extent than others. But even if the affects of temperature could be precisely known in all of the many different REDOX reactions, it would not be desirable to remove them from the measurement. True ORP is the direct measurement of electrons in transit during Oxidation-Reduction reactions, regardless of temperature.

Technical Reference Section: pH/ORP

Principle of Operation

- Standard pH/ORP electrodes** are also commonly called combination electrodes; a pH/ORP measuring electrode and a reference measuring electrode are combined in a single body. The pH/ORP sensor measures the amount of hydrogen ions in the liquid. The pH signal is measured against the steady reference signal. Various chemical elements leaching through the porous reference junction can react with the reference electrolyte, dilute the electrolyte solution, or attack the silver chloride element; in either case, it will disturb the steady reference signal. Stray electrical currents will also affect the steady reference signal. A temperature element is also built into the pH/ORP combination electrode. Instruments interpret and temperature compensate the pH/ORP and reference signals into pH/ORP readings at 25°C (77°F).

Signet offers three different groups of Standard pH/ORP Electrode Models: Models 2714-2717, 2754-2757, and 2774-2777

Cutaway of 2716 pH electrode

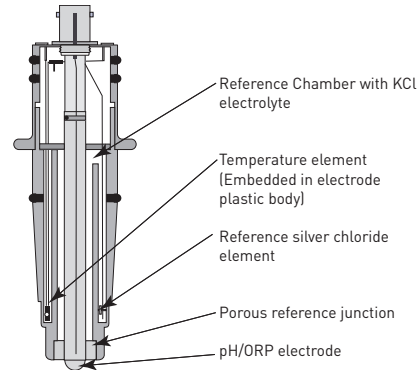

Cutaway of 2776 pH electrode

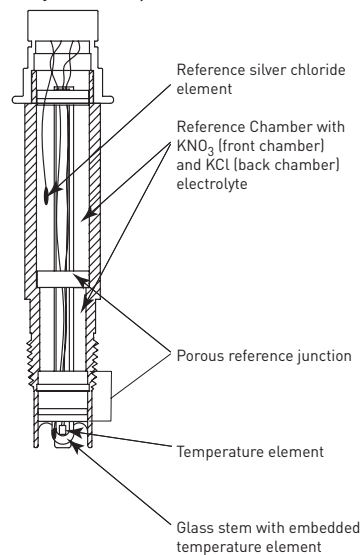

- Differential pH/ORP electrodes** function similar to the standard (combination) electrodes, but the reference design is modified and there is a third electrode, the solution ground. The pH and reference electrodes are measured against the solution ground. The solution ground drains stray currents away from the reference element, hence maintaining a steady signal at all times. The reference salt bridge slows or stops various chemical elements from leaching into the reference chamber. Chemicals that leach in may dilute the electrolyte but will not react with the glass-encased reference silver chloride element. The reference electrolyte can be refreshed if it is diluted or depleted. The temperature element is embedded in the pH/ORP electrode for an extremely quick response.

Cutaway of 2766 pH electrode

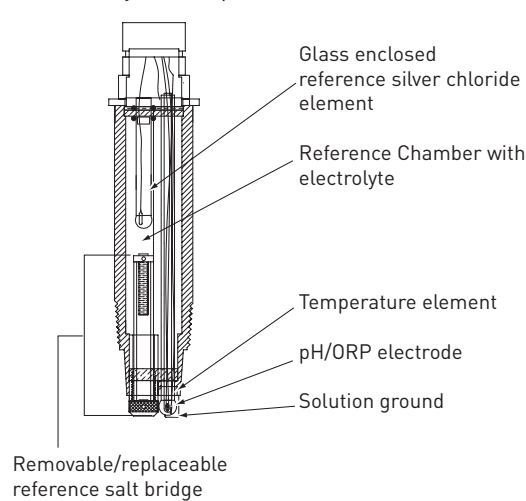

Signet offers one group of Differential pH/ORP Electrodes: Models 2764 - 2767

Technical Reference Section: pH/ORP

Standard versus Differential pH/ORP Electrodes:

Signet offers what is called combination pH/ORP electrodes; a combination of three or four electrodes built into one common body that measures the pH or ORP of the solutions. These electrodes are the pH/ORP sensing element, temperature sensing element (pH only), the reference, and sometimes a solution ground. An electrical path between the process solution, reference electrode, and the pH/ORP sensing electrode must always be present to complete the measuring circuit. When the circuit is broken or interrupted, the result is a faulty reading. There are only a few things in a chemical process that would affect the glass-sensing element. These include concentrations of HF, constant high temperatures, and particles that can break the glass.

On the other hand, there are many problems that can occur with the reference electrode. The reference silver chloride sensing element (wire) is exposed to the process liquid via the primary porous reference junction, which is in constant contact with the process and allows liquid to pass through to the reference electrolyte. Because of the direct contact with the process liquid, the reference electrolyte and reference silver chloride sensing element can react with chemicals in the process. Many application liquids do not chemically react with the reference and therefore a standard electrode will perform well in this scenario. However, there are other process chemicals that will easily attack the reference and therefore, a differential style electrode should be used. There are three advantages of the differential electrode:

1. If the process chemicals attack the KCl electrolyte, the reference electrolyte chamber is refillable.
2. If the reference junction becomes clogged by chemical reactions between the KCl and the process chemicals, the reference salt bridge is replaceable.
3. If there are stray currents or if there are process chemicals that attack the silver chloride wire in the standard electrodes, it will not attack it in the differential electrode because the wire is encased in a glass electrode.

A general rule of thumb is to use a differential electrode if you have mercury, copper, lead, chlorate, bromine, iodine, cyanide, or sulfide compounds in the process liquid. Differential electrodes may also be useful in processes where oil, grease, and dirt build up on the reference junction because it is easily replaced.

See Model 2764-2767 Differential pH/ORP catalog pages for more information on standard versus differential electrodes.

Technical Reference Section: pH/ORP

Important Application Tips

- It is important that the sensing end of pH and ORP electrodes remain wet, for they may be permanently damaged if allowed to dehydrate. This is true for both in-line and submersible installation configurations. However, be careful to keep the electrical interconnection between electrode and preamplifier dry and clean at all times. Moisture in this area can also cause permanent damage.
- pH control is best when performed in a tank. This is especially true in neutralization applications since it is very important for reagents to mix thoroughly with waste fluids, and to be allowed adequate time for the reactions to occur. Limiting adjustments to fewer than 3 pH units per stage, and sizing tanks to provide at least 10 minutes retention time, will increase the probability of producing safe effluents.
- For bulb-style pH and ORP electrodes, significant natural self-cleaning by turbulent eddies is achieved at velocities of 1.5m/s or more (5 ft/s). Flat surface electrodes get adequate self-cleaning at velocities of 0.3 to 0.6m/s (1 to 2 ft/s). In all cases, exposure to velocities greater than 3m/s (10 ft/s) can cause excessive measurement noise and electrode wear and should be avoided.
- The aging of pH and ORP electrodes (i.e., reference depletion and decreased glass sensitivity) results from a series of chemical reactions. And as a general rule, the rates of chemical reactions double with every increase of 10°C (50°F). This means shorter life expectancy for all pH and ORP electrodes as application temperatures increase.
- HF acid and strong caustics etch pH glass. High concentrations, especially at high temperatures, destroy electrodes quickly. For applications containing trace quantities of HF (<2%), use the Signet 3-2714-HF or 3-2754-HF electrode. This electrode has a polymeric constituent in the pH glass that resists attack by HF and extends the service life considerably over “normal” electrodes.
- In applications where process temperatures will drop below 10°C (50°F), use the bulb-style electrodes in place of the Flat style electrode. This is a function of the electrical impedance of the glass that increases dramatically as temperature decreases.
- Proper electrode placement within a tank is also very important. Electrodes should be mounted in well-mixed areas, away from reagent and waste introduction. It is usually advisable to position the electrode near the discharge outlet of the tank.
- In-line pH control is not recommended because it is very difficult to determine the amounts of reagent necessary to achieve a desired reaction if both pH and flow are variables. However, in-line pH monitoring is very common and useful.

Technical Reference Section: pH/ORP

Maintenance Tips

- Cleaning pH and ORP electrodes and calibrating the systems should be done regularly. The required frequency is application-dependent, but once/week for cleaning, and twice/month for calibration is recommended.
- Isopropyl alcohol may be used for removing mild grease and oils from the pH sensitive glass or from the metallic tips of ORP electrodes. Use 5% HCl on porous reference junctions clogged with hard water deposits, or other solvents/detergents as necessary. Always consider the electrode's materials of construction when selecting a cleanser.
- The purpose of calibration is to compensate the system for the continual changes occurring within the electrodes. Like batteries, all pH and ORP electrodes eventually deplete and must be replaced. A good time to determine the condition of an electrode is after cleaning and during calibration. Note the mV readings in pH buffers and replace the electrode if its actual mV output differs more than 50 mV from these theoretical values: pH 7 = 0 mV, pH 4 = +177 mV, pH 10 = -177 mV. Replace an ORP electrode if its actual mV output differs more than 50 mV from the theoretical values in the table below:

ORP Values of Standard pH Buffers Saturated with Quinhydrone

	pH4			pH7		
Temperature (°C)	20	25	30	20	25	30
ORP Value (mV)	268	264	258	92	87	79

- The typical shelf-life recommendation for Signet pH and ORP electrodes is 12 months at 25°C (77°F).
- Refrigeration will extend this period, but do not allow them to freeze! Expansion of internal solutions during freezing can cause permanent damage to the electrodes.
- The risk of putting older electrodes into service is the possible disappointment of shorter than expected service-life. All Signet pH and ORP electrodes are marked with date codes to identify the date of manufacture.

Technical Reference Section: Conductivity/Resistivity

Information in this section addresses frequently asked questions regarding Conductivity (Resistivity) and is provided as REFERENCE ONLY to supplement procedures and recommendations specifically outlined in individual product instruction manuals.

All manuals, data sheets, and additional helpful information are available at www.gfsignet.com.

Definition of Conductivity and Resistivity

Conductivity is a measure of the ability of a material to convey an electric current. The proper term for this ability of a solution is electrolytic conductivity, since only ions conduct electric current in solution. When dissolved in solution, many substances such as salts, acids and bases dissociate into ions. Electrolytic conductivity (or simply conductivity) is therefore an indirect measure of the ionic concentration of a solution. Generally, conductivity increases and decreases with the concentration of ions.

Unlike pH, which is a specific measure of Hydrogen ion concentration, conductivity is a non-selective measurement of all the dissolved ionic species in a solution. As such, it is a highly utilized parameter in water, wastewater and industrial process analyses. For example, conductivity is used to monitor the salt load of waters entering treatment facilities, to monitor and control the quality of drinking water and ultra-pure water, and to otherwise detect contaminants in industrial processes.

According to the International Standards Organization (ISO) the unit of conductance is the Siemens (S), after Werner von Siemens (1816-1892). However, the following three separate units of measure are commonly used to express conductivity: Siemens/cm (S/cm), mhos/cm, and $\mu\text{S/cm}$. For any given measurement Siemens/cm and mhos/cm are exactly equal;

they are merely different labels for the same value. The denominator in these units (cm) is sometimes truncated but is always assumed to be present.

Ohm•cm is a unit of resistivity (the inverse of conductivity) and is frequently replaced by “ Ω ” the symbol for electrical resistance. Units of resistivity are most commonly associated with ultra-pure water measurements in the millions of ohm•cm, or M Ω (megohms).

Some users will also find it desirable to express conductivity in terms of parts per million (PPM) or parts per billion (PPB) of total dissolved solids (TDS). Signet instruments accommodate this by allowing the entry of a TDS factor to convert from standard units of conductivity. (See the instruction manual of any current Signet conductivity instrument for details.)

Conductivity is a measurement parameter with a very wide range. For example, ultra-pure water has a theoretical maximum resistivity of approximately 18.2 M Ω , approximately 0.055 μS (microsiemens), whereas concentrated acids and bases can exceed 400,000 μS . Despite the wide-ranging possibilities most applications for conductivity measurement are much narrower. Tap water, for instance, typically measures between 50 and 1,000 μS .

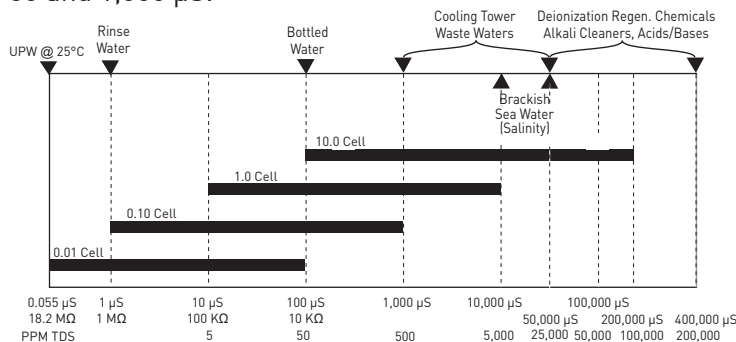

Technical Reference Section: Conductivity/Resistivity

Principle of operation

Most conductivity electrodes consist of two measuring half-cells. The geometry of the half-cells can be tailored to provide highly accurate measurements over a specific conductivity range. Cell constants help to describe electrode geometry for the purpose of selecting the appropriate electrode for a given application. A cell constant is defined as the length between the two half-cells divided by the area of the cells.

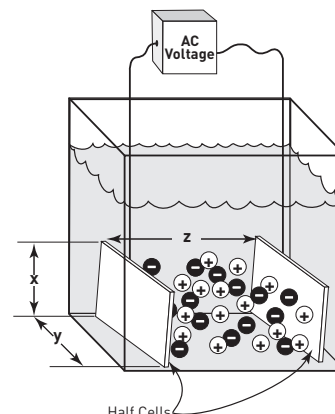

* CSA is cross sectional area.

$$\text{Conductivity Cell Constant} = \frac{\text{Length}}{\text{CSA}^*} = \frac{z}{xy}$$

As an example, When $x = y = z = 1\text{cm}$ the cell constant becomes $\frac{1\text{cm}}{1\text{cm}^2} = 1\text{cm}^{-1}$

Solutions of very low conductivity (high resistivity) such as ultra-pure water are best measured with half-cells that are very close together (i.e., cell constant = 0.01cm^{-1}). Highly conductive solutions should be measured with half-cells that are farther apart and that have relatively little cross sectional area between them (i.e., cell constant = 20.0cm^{-1}).

Temperature Compensation

The conductivity of a solution is highly dependent upon temperature. Therefore, conductivity measurements are almost always converted to an equivalent conductivity at the common reference temperature of 25°C (77°F). This is accomplished by means of temperature compensation algorithms in the instruments, which require temperature as well as conductivity measurement input. To simplify and facilitate this requirement all Signet conductivity electrodes contain high-quality temperature sensing elements intelligently positioned for quick and accurate response.

Temperature effects on conductivity are more or less linear for normal water-based solutions, hovering around 2% per $^\circ\text{C}$. However, the actual linear relationship varies con-

siderably with the ionic composition of the solution and can range from less than 1% to more than 3% per $^\circ\text{C}$. This is true of regional ground water sources as well as for other solutions such as brackish water, acids and bases. Signet instruments allow the entry of custom linear compensation coefficients for these applications. See the instruction manual of any Signet conductivity instrument for details.

The conductivity or resistivity of pure water is not a linear function with respect to temperature. In fact, the latest Signet conductivity instruments utilize a sophisticated polynomial to compensate for the peculiar effects. For seamless measurement accuracy all current Signet conductivity instruments switch automatically between linear and pure-water compensation as certain measurement thresholds are crossed.

Temperature Compensation Exception

One exception to the requirement for temperature compensation has been established by USP (United States Pharmacopeia), which prescribes limits of acceptability for ultra-pure water quality based upon non-compensated measurements. This methodology is used to eliminate measurement variances that may result from differences in the pure-water temperature compensation algorithms used by different manufacturers of conductivity measurement equipment. A more thorough treatment of the USP standard and instrument functionality can be found in the instruction manuals of the following Signet conductivity instruments: Model 8900 Multi-Channel, Multi-Parameter Controller (Appendix D), model 8860 Dual Channel Conductivity/Resistivity Controller.

Relay Information

The two most common methods of controlling a process are “on/off” and “proportional” control. In on/off control, relay setpoints are defined as either high or low limits on the process variable. When the measurement value reaches a limit the relay is energized, typically for the purpose of opening a valve or starting a pump to introduce a chemical reagent to the process. This should cause the measurement value to change in the direction of the setpoint as shown in these on/off control diagrams:

High limit on/off relay control

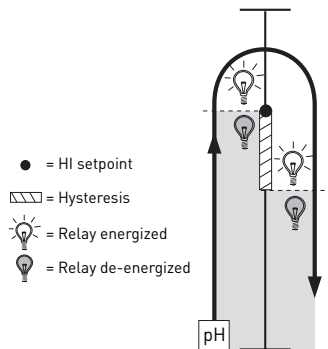

Low limit on/off control

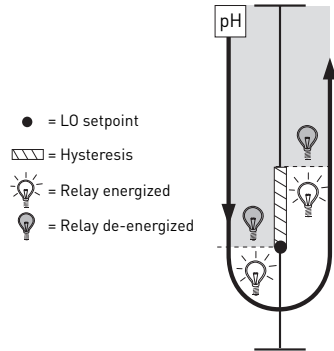

Notice the relay will not de-energize until the setpoint is exceeded by the hysteresis value. This is a programmable value and is primarily used to prevent “relay chatter”, which occurs if a relay is set to energize and de-energize at the same value. Because of hysteresis, and because reagent delivery is fairly constant while the relay is energized, a condition known as “overshoot” is inherent to the on/off control method. Overshoot refers to the introduction of more chemical reagent than is absolutely necessary for achieving a desired adjustment to the process value, and can be expensive over time.

Proportional control is a popular alternative to the on/off control method. This method typically makes use of variable-rate metering pumps to reduce overshoot and improve precision. Establishing a proportional control scenario requires the selection of setpoint(s), deviation

range(s) and maximum pulse rates. The example shown here illustrates how two relays in “pulse mode” can be used to proportionally control pH within a desired range, or to a single setpoint. This is called “Dual Proportional Control”. Of course, a single relay in proportional pulse mode can be used to establish a high or low limit and will also reduce overshoot.

Metering pumps are idle at and between setpoints. When a setpoint is exceeded, the pump begins delivering reagent at a rate proportional to the difference between the measurement value and the setpoint. The larger the difference, the faster the delivery. The programmed deviation value defines how quickly the maximum pulse rate is reached. Depending on the input requirements of the metering pump, proportional control can also be accomplished with scaleable 4 to 20 mA outputs instead of pulsing relays or open collectors.

Dual proportional pulse relay control

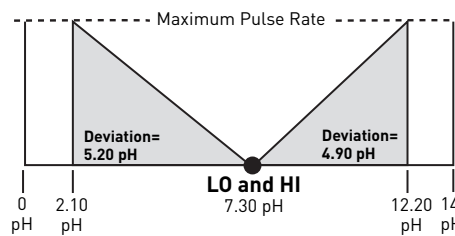
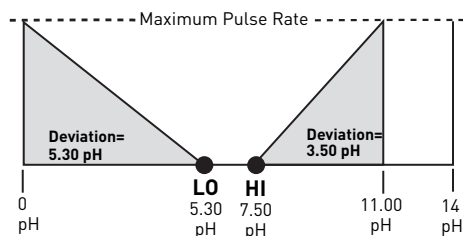

Open Collector Output

Many Signet instruments and sensors feature “Open Collector Outputs” for purposes of signal transmission, alarming, control signal output, etc. Although such outputs allow for a lot of wiring flexibility, care must be taken not to destroy the circuits via incorrect polarity, over-voltage, transients or current overload. Below is an explanation of proper wiring and dimensioning of related circuit components. Please note that the following recommendations may or may not apply to other manufacturer’s equipment.

1. Function

Open Collector (“OC”) outputs are low powered, solid state switches. Although the term “Open Collector” stipulates the use of bipolar transistors (NPN-type or PNP-type) as a switch, nowadays Field Effect Transistors (FET or MOSFET) are used. Unlike electromechanical switches (e.g. pushbuttons or dry contact relays) these OC switches are very fast, use little power, are inexpensive, do not bounce and do not wear. However, OC’s are also more limited in terms of voltage and current rating as well as being polarized (i.e. they have a “plus” and “minus” terminal and thus DC only switching capability). They are less tolerant to overload abuse than electromechanical devices. Usually these switches have higher resistance and voltage drop.

2. Sensor Wiring

A typical example of the need for high speed switching capability is the OC frequency output of Signet flow sensors like 3-2536 or 3-2540. Signal frequencies can reach several hundred pulses per second while voltage and current requirements are small enough, allowing the use of a transistor switch. For each output pulse this switch connects the signal output to the negative supply or ground terminal of the sensor and is therefore an “NPN” style output. Signet does not produce sensors with PNP style outputs (which connect the signal output internally to the positive supply terminal).

Most indicating instruments or control system inputs require a signal voltage of 0 to 5V (TTL or CMOS logic levels) or 0 to 24V. Therefore, Open Collector output circuits must be complemented with a “Pull-Up-Resistor” to function properly. Please see the following example diagram for wiring with a PLC input:

Do not exceed the absolute maximum voltage rating of the OC output as listed in the sensor specifications, normally 27 or 30 Volt, DC only. This includes changes to power line fluctuations, transients or power supply instability, otherwise damage to the OC will occur.

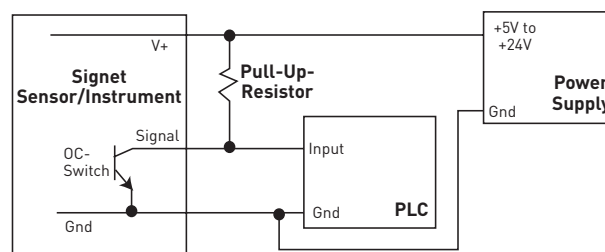

Please note that the voltage connected to the positive sensor supply (V+) must correspond to the required high-level PLC input voltage (i.e. if the high-input voltage of the PLC is 24V, then the pull-up must be supplied with 24V). If the input is “TTL-Level” or “CMOS-Level”, that means 5V for high level, then the pull-up should not be connected with a supply higher than 5V.

Signet instruments already have the pull-up-resistor and the sensor power supply built into the instrument. No external pull-up-resistors are required.

Open Collector Output (continued)

3. Instrument Output Wiring

Open collector control and alarm outputs on Signet instruments (i.e. ProcessPro® or ProPoint™ series) are electrically isolated from the instrument's power supply. That means these can be used in the above mentioned NPN configuration as well as in PNP configuration, if required. Below are a few sample circuits:

- PLC Wiring "NPN" style

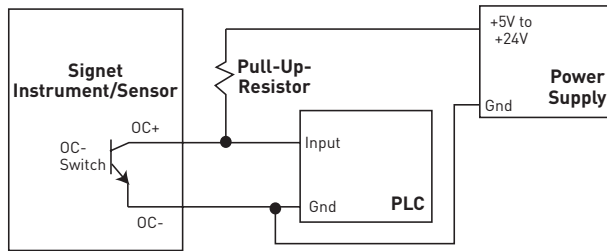

- Alarm circuit or alarm lamp wiring to a single Signet instrument

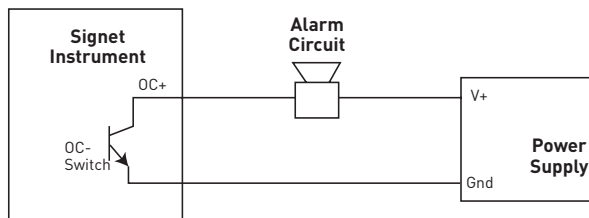

- Alarm circuit or alarm lamp wiring to serve multiple Signet instruments
 - Triggers the alarm if any one of the instruments open collector outputs are on.

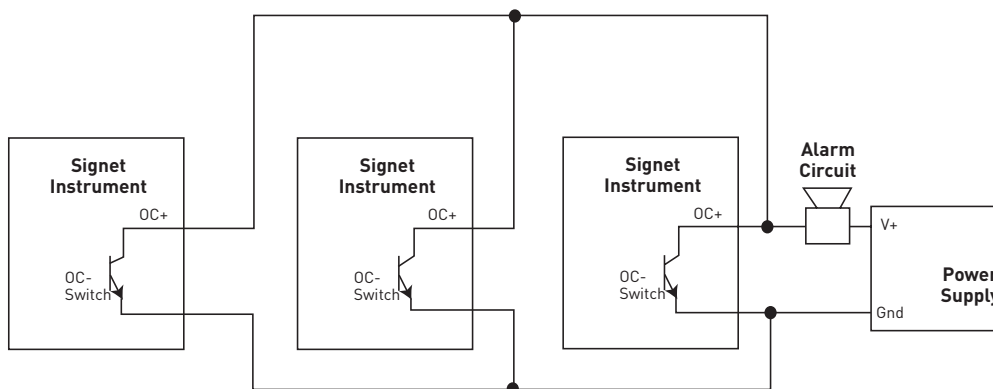

Open Collector Output (continued)

4. Voltage and Current Limitation

As mentioned before, the supply voltage in the OC output circuit MUST be limited to the specified maximum OC voltage (see operating manual for specific instrument). The use of a quality regulated 5V, 12V or 24V (depending on the application) power supply is recommended.

The current through the Open Collector switch must be limited. Typical OC outputs allow only for 10 to 50mA switch current (please consult manual). Exceeding this current limit can burn out the OC output components immediately. Please see the following section on how to dimension the loads.

5. Load and Pull-Up/Down Resistor Considerations

By utilizing basic arithmetic and Ohm's law, one can determine the safe limits of load resistance. When the OC switch is closed, almost the entire supply voltage is applied to the load, (i.e. the pull-up or pull-down resistor, the alarm horn input, a potential power relay coil or annunciator lamp). The resulting current through the load and through the OC switch, as well, can be calculated as:

$$(\text{Current}) = (\text{Supply Voltage})/(\text{Load Resistance})$$

- Example 1:

The supply voltage is 24V and a pull-up-resistor of 10k Ω is used.

Current is $24/10,000 = 2.4\text{mA}$

(If the OC current rating is 10mA, then in this example, it would be considered safe.)

- Example 2:

The supply voltage is 12V and a horn with a resistance of 100 Ω is used

Current is $12/100 = 120\text{mA}$

(Even if the OC current rating is 50mA, this load will damage the instrument)

6. Transient Protection

There are several "difficult" load cases that must be considered:

- Inductive loads:
These can be power relay or other solenoids, motors, alarm horn coils, etc. Such loads generate very high voltage spikes everytime the load switches. If such a load is unavoidable, the use of transient suppression components, or Signet RC-Filters (3-8050.396), or snubbers, wired parallel to the load is required. This is critical, as a single transient pulse may destroy the output.
- Capacitive loads:
This type of load should be rare but can occur if the load contains an internal power supply/regulator that is fed from the output circuit. In such a case, it must be assured that the in-rush current does not exceed the OC current rating.
- Incandescent lamps:
Such lamps have a very high start-up current until the filament glows and the current settles to the specified value. The use of incandescent lamps on an OC output is not recommended. An LED type annunciator should be used instead.

Open Collector Output (continued)

7. “Active High” and “Active Low” Setting

Depending on the desired function of the circuit attached to the OC output, it may be necessary to have the OC output switch turned “on” or “off” when the criteria for the activation of this output are met.

By default, Signet instruments are set to operate in “active low” mode. This means when the user-defined condition for the activation is met (e.g. exceeding of an alarm limit) the OC switch is turned “on”. If wired as standard “NPN-style” output (see previous page) the logic level of the attached control system or PLC input consequently becomes “low” logic level.

If a high input logic level is required for activation, it can be accomplished by changing the OC output function to “active high” in the menu system of the instrument. Most Signet instruments allow for this option.

8. Fail-Safe Behavior

No matter what the setting, most OC outputs of Signet instruments turn off when the instrument loses power. This must be taken into account when evaluating system failure consequences. If the system layout requires a “closed” or “on” condition for the output in case of power loss, a mechanical dry contact relay (NC contacts) must be used instead of the OC output.