

# Signet 3300/3500 Ultrasonic Flow Monitor System **+GF+**



## Description



The Signet 3300 Ultrasonic Flow Monitoring System advances the use of Doppler ultrasonic technology in flow measurement by utilizing proprietary "Advanced Spectrum" signal processing to measure the entire flow stream. The result is reliable, power-efficient, low cost of ownership, liquid flow monitoring in open or closed channels.

The Signet 3300 includes features tailored to meet common requirements in a variety of applications like municipal water/wastewater, industrial waste, etc.

The Signet 3300 system can be equipped with a 4 to 20mA output for interfacing to loggers, telemetry systems or PLC's for long-term monitoring or an RS232 local connection to laptops or pocket PCs. This vandal-resistant unit is dual password protected, one for viewing data and one for programming. Both velocity and velocity/depth combination sensors have no moving parts and lend minimal obstruction in the flow stream.



## System Overview

Strap-in Sensor Mount	Insertion Sensor Mount
<p>Signet Flow Instrument 3-3300 (-1)</p>  <p>Mounting Kit included</p>	
<p>Signet Flow Sensor 3-3500.312 3-3500.313 (Pipe sold separately)</p> 	<p>Signet Flow Sensor 3-3500.320 3-3500.330</p> 
<p>Strap mount kit included *Not for large pipes</p>	<p>Pipe fitting (customer supplied)</p>

## Features

- Bi-directional flow
- Measures debris laden flow
- Open channel or full pipe measurements
- Self-diagnostics
- Local display of flow rate and total
- Minimal straight run requirements
- No moving parts
- Battery powered (optional solar panel)
- High-intensity proportional flashing rate indicator
- Weatherproof stainless steel enclosure
- Vandal-resistant
- PC/Pocket PC access and downloads
- Data logger
- Optional 4 to 20mA outputs (dependant on user defined rate)
- Wet-Tap capability

## Applications

- Industrial/Municipal Wastewater
- Pump Station Monitoring
- Environmental Monitoring
- Billing Networks
- Sewer and Stormwater Flow Monitoring
- Open channels, Flumes, and weirs

# Dimensions

## 3300 Monitor Logger

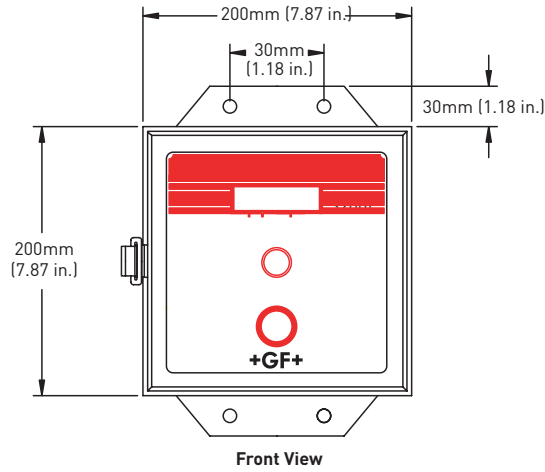

## Solar Panel (optional)

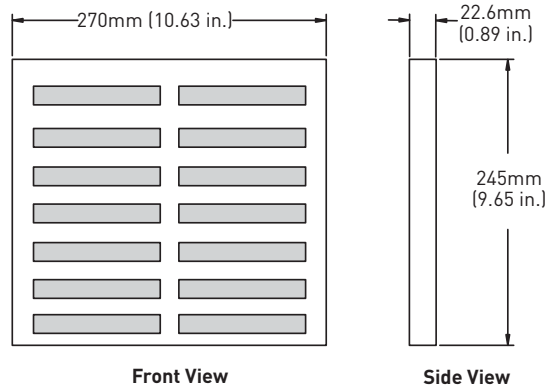

## Insert Transducer

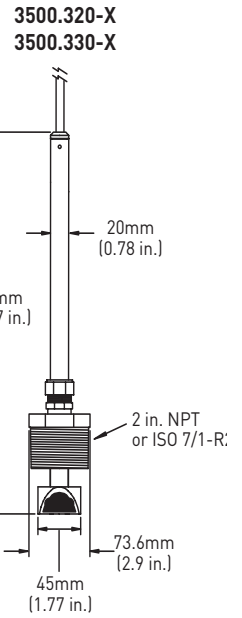

## Strap Mount Transducer

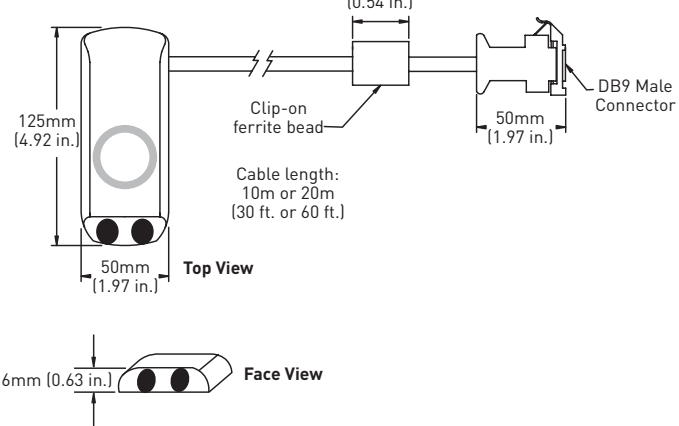

# Specifications

## 3300 Flowmeter

### General

#### User Interface:

- Flow display is an internal 6-digit, 0.5 in. (12mm) LCD of constant status, flow rate and flow volume total
- High-intensity LED light flashes proportionately to flow rate (user configurable)
- RS232 serial cable for local connection to PC, laptops and pocket PC
- RS232 null modem cable for local connection to PocketPC (optional)  
Note: Pocket PC not included  
Recommended Pocket PC with software 2002 OS/CE 3.0 or later, and null modem cable.

#### Flow Volume Logging Capacity:

- Configuration dependent to maximum of 250,000 records at 15 min. intervals. Includes independent logging of depth. Over 120 days data logging.

### Material:

316 Stainless Steel (1.4401) enclosure

### Electrical

#### Power:

- 9VDC- 1 amp, regulated power converter required for 110 VAC/240 VAC operation. Internal battery used as backup.
- Internal 6V 12 Ah battery, rechargeable (charger is customer supplied) Solar panel available\*

#### Outputs:

- Pulse Output: open-collector flow volume pulse, which shorts pulse pin to system ground\*\*
- 4 to 20 mA output

#### Alarm:

Short Message Service Protocol (SMS)

#### Program Memory:

Battery backed NVRAM

#### Units of Measure:

User definable for rate and total (in metric or English units)

#### Application Software (required)

- CD-ROM included with required FloCom™ for PCs with help files, user manual, installation instructions, system configuration, data downloading & velocity profile testing. Minimum PC requirements - Windows® 98 or newer, 10MB hard drive disk space, one serial comms port (must be COM1 or COM2), at least 640 x 480 resolution std. VGA screen
- Optional FloCom™ CE Software available for use with PocketPC

### Environmental

Enclosure Rating: IP66

Operating Temperature:

23°F to 122°F (-5°C to 50°C)

## 3500 Series Sensors

### General

#### Velocity Performance - all sensors

- Velocity Measurement Method: Wetted Doppler
- Bi-directional flow display (fully accountable), reverse flow indication and net flow calculation
- Velocity Range (strap mount and insertion type sensors): 0.03m/s to 4m/s (0.1 ft/sec to 13 ft/sec)
- Velocity Accuracy: ±1% of value up to 3.0m/sec (9.8 ft/sec) ±1.5% of value at velocities greater than 3.0m/sec (9.8 ft/sec)
- Repeatability: 0.5% @ 1m/s (3.2 ft/s)
- Velocity Resolution: 1mm (0.04 in.) @ 1m/sec (3.3 ft/sec)
- Max. operating temp./pressure: 10 bar @ 25°C (147 psi @ 77°F)

#### Depth Measurement Performance

(3-3500.312, 3-3500.313)

#### Depth Sensor Ranges:

- 4m (13.1 ft.)
- 10m (32.8 ft.)
- Max. depth (over range): 60m (197 ft.) without damage

#### Depth Sensor Accuracy:

0.2% of full scale at constant temperature in a static stream (depth measurement only).

1% of full scale over a flow stream (5°C to 55°C)

Repeatability: 0.5% at 1m/s (3.2 ft/s)

#### Depth Sensor Resolution: 1mm (0.04 in.)

- Max. operating temp./pressure: 10 bar @ 25°C (147 psi @ 77°F)

#### Mounting

- Installation Distance: 6x diameter and 2x diameter (reversible - up or down stream)
- Insertion sensor fitting: 2 in. NPT threads or ISO 7/1-R2 threads
- Insertion Installation Limits: DN100 to DN1800 (4 in. to 72 in.)

### Wetted Materials

- Strap Mount: Epoxy and PVC
- Pressure transducer: Alumina ceramic
- Insertion Mount: Epoxy and nickel plated brass or 316 stainless steel
- Cable: PVC 9 mm diameter from 10m (33 ft.) to 50m (165 ft.)

### Shipping Weight (Flowmeter and Sensor):

9 kg (21 lbs.)

### Standards and Approvals:

- CE

\* Optional battery-solar panel for trickle charge stand-alone power system. Approximate life expectancy is 7 years, depending on application conditions.

\*\* One pulse/volume unit independent of integration time period.

## Ordering Information

Electronics Package (required) - Used with any of the sensors listed below	
<b>3-3300</b>	Ultrasonic Doppler flow meter electronics package; includes display electronics, mounting hardware, back-up battery, communication serial cable, set-up CD and software
<b>3-3300-1</b>	Ultrasonic Doppler flow meter electronics package; includes display electronics, mounting hardware, back-up battery, communication serial cable, set-up CD and software, with one 4 to 20mA output.

Sensor Part Number (required) - Choose one		
<b>3-3500</b>	Ultrasonic Doppler Flow Sensor - must be used with 3-3300 Electronics package - Choose one	
↓	<b>.312</b>	Strap-in sensor, 0 - 4 m (0 - 13.1 ft) depth measurement above transducer face
	<b>.313</b>	Strap-in sensor, 0 - 10 m (0 - 32.8 ft) depth measurement above transducer face
	Cable length for strap-in sensor	
	<b>-1</b>	10m (33 ft) cable
	<b>-2</b>	20m (66 ft) cable
	<b>.320</b>	Insertion sensor, nickel plated brass
	<b>.330</b>	Insertion sensor, 316 stainless steel (1.4401)
	Cable length and thread size for insertio sensor - choose one	
	<b>-1</b>	10 m (33 ft.) cable for both styles; 2 inch NPT threads
	<b>-2</b>	20 m (66 ft.) cable for both styles; 2 inch NPT threads
<b>-3</b>	10 m (33 ft.) cable for both styles; ISO 7/1 R-2 threads	
<b>-4</b>	20 m (66 ft.) cable for both styles; ISO 7/1 R-2 threads	
<b>3-3500</b>	<b>.312</b>	<b>-2</b> <b>Example Part Number</b>

Sensor Strap Styles - Choose one (required)	
<b>3-3500.390</b>	Adjustable strap poly - 300mm to 450mm pipe
<b>3-3500.392</b>	Strap-in sensor mounting plate - polypropylene; used for pipes > 450mm
<b>3-3500.393</b>	Adjustable strap poly - 225mm to 300mm pipe

Mfr. Part No.	Code	Mfr. Part No.	Code
<b>Electronics</b>		<b>Sensors</b>	
3-3300	<b>159 000 989</b>	3-3500.320-3	<b>159 001 001</b>
3-3300-1	<b>159 001 499</b>	3-3500.320-4	<b>159 001 002</b>
<b>Sensors</b>		3-3500.330-1	<b>159 001 003</b>
3-3500.312-1	<b>159 000 994</b>	3-3500.330-2	<b>159 001 004</b>
3-3500.312-2	<b>159 000 995</b>	3-3500.330-3	<b>159 001 005</b>
3-3500.313-1	<b>159 000 996</b>	3-3500.330-4	<b>159 001 006</b>
3-3500.313-2	<b>159 000 997</b>	<b>Sensor Straps*</b>	
3-3500.320-1	<b>159 000 998</b>	3-3500.390	<b>159 000 986</b>
3-3500.320-2	<b>159 000 999</b>	3-3500.392	<b>159 000 984</b>
		3-3500.393	<b>159 000 987</b>

## Accessories and Replacement Parts

Mfr. Part No.	Code	Description
3-3300.100	<b>159 000 972</b>	3300 Electronics only - No 4 to 20 mA output
3-3300.100-1	<b>159 001 500</b>	3300 Electronics only - With 4 to 20 mA output
3-3200.075	<b>159 000 973</b>	Battery - sealed lead acid 6V 12 Ah* (Panasonic LC-R0612P)
3-3200.076	<b>159 000 975</b>	Solar panel - Solarex 6V 5W MSX5V6
3-3200.395	<b>159 000 976</b>	Solar panel mounting kit
3-3200.090	<b>159 000 977</b>	Signet FloCom™ CD Doppler operating system and instructions (Win32)*
3-3200.091	<b>159 000 978</b>	Signet FloCom™ CE CD for Pocket PCs (Note: Null modem adapter and pocket PC not included)
3-3200.391	<b>159 000 979</b>	Communication cable 3300 to PC - DB9 serial cable*
3-3200.392	<b>159 000 980</b>	Communication cable 3300 to Pocket PC (null modem)-Not a stocked item
3-3200.393	<b>159 000 981</b>	One 4 to 20mA output module, internally mounted

### Model 3300/3500

#### Ordering Notes:

- 1) Select a Doppler Flow meter with or without a 4 to 20mA output
- 2) Select a sensor: strap-in or insertion
- 3) Select strap: mounting plate or adjustable strap
- 4) Optional 30 m (100 ft.) and 50 m (165 ft.) cable lengths available. Call factory for details.
- 5) All strap-in sensors measure depth and velocity, and are the perfect choice for open channels.
- 6) Insertion sensors do not measure depth. They are for full pipe applications only.
- 7) PDA/Pocket PC is not included. See specification for recommendations.
- 8) Select a 4 to 20mA output for interfacing to loggers, telemetry, or PLCs.
- 9) For 110VAC/240VAC operation, a power supply to 9VDC/1 amp is required (customer supplied). It will trickle charge the internal battery. In the event of a power failure, the battery will ensure continuous data logging.

- 9) Minimum pipe size for installation of strap-in and insertion sensors is DN 100 (4 in.). Maximum pipe size for insertion sensors is DN 1800 (72 in.)

\* All hardware is included.