

+GF+ SIGNET 3-8800

Conductivity Transmitter



Instruction Manual

GEORGE FISCHER +GF+

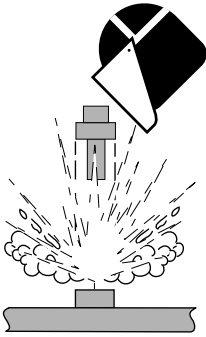

SAFETY INSTRUCTIONS

1. Do not remove from pressurized lines.
2. Do not exceed maximum temperature/pressure specifications.
3. Do not install/service without following installation instructions (see sensor manual).
4. Wear safety goggles and faceshield during installation/service.
5. Do not alter product construction.
6. Failure to follow safety instructions could result in severe personal injury!

Chapter

Page

Table of Contents

1	Introduction	1
1.1	Description	1
2	Calibration	3
2.1	Wet Calibration	3
2.2	Calibration Procedure	4
2.3	Installing Optional Display Board	5
2.4	Display Board Range Adjustment	6
3	Installation	7
3.1	General	7
3.2	Positioning	7
3.3	In-Line Installations	8
3.4	In-line Fitting Options	8
3.5	Submersible Installations	10
3.6	Electrical Installation	11
4	Conductivity Sensor Maintenance	13
4.1	Maintenance Tips	13
4.2	Replacement Parts	14
4.3	Troubleshooting Guide	15
	Specifications	16
	Dimensional View	17
	Warranty	18

Unpacking and Inspection

The following items are included in your Conductivity transmitter package:

- 8800 Conductivity Transmitter 3-8800.103-XX
- Instruction manual 3-8800.090

Please fill out and return the warranty card as soon as possible.

-XX Refers to electronic range options:

-1P= 0 to 20 μS , 0.5 cell

-2P= 0 to 200 μS , 0.5 cell

-3P= 0 to 2,000 μS , 2.0 cell

-4P= 0 to 10,000 μS , 2.0 cell

Warranty record

For your protection, record the purchase information for future reference. The serial number decal is located within the enclosure

Model: +GF+ SIGNET 8800 Conductivity Transmitter

Purchase date: _____

Serial number: _____

Purchased from: _____

Purchase order number: _____

Chapter 1 Introduction

This manual contains description, instructions and specifications for the installation, calibration and care of the +GF+ SIGNET 8800 Conductivity Transmitter. Should you require further assistance, please contact your +GF+ SIGNET dealer.

1.1 Description

The +GF+ SIGNET 8800 Conductivity system is used in conjunction with an insertion type sensor that continuously measures the conductivity (total dissolved solids or gases) of a solution in a wide variety of process applications.

The Conductivity Transmitter consists of a conductivity sensor and an electronics package (transmitter). The electronics package is housed in a NEMA 4X/IP65 enclosure.

The +GF+ SIGNET 8800 transmitter system can be converted for submersible applications such as water wells, tanks etc. Optional submersion kit, p/n 3-2700.391 includes the necessary parts and assembly instructions for extending the sensor length up to 12 ft. The submersible kit requires a 3/4 inch pipe with male NPT threads on both ends, (user supplied) that is used to physically extend the sensors' length.

The submersion kit also requires an extended cable, (purchased separately) which is used to interface the sensor to the electronics. Optional extension cable p/n 3-8800.261-XX (-03, -06, -09 or -12 ft.). Refer to Figure 1 below:

Figure 1

Transmitter submersion kit and required extension cable.

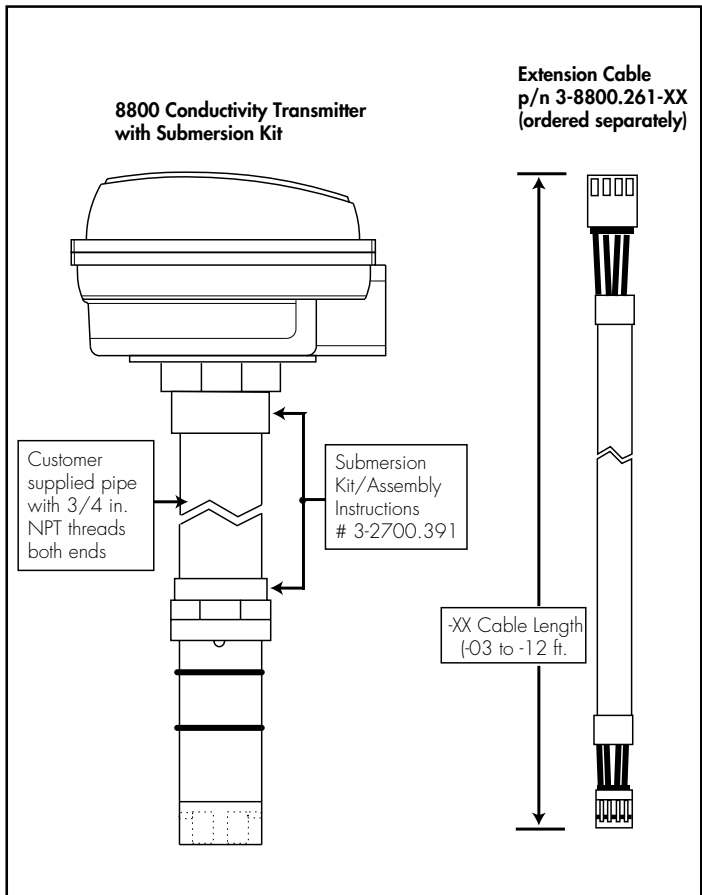

Chapter 2 Calibration

2.1 Wet Calibration

Your 8800 Conductivity transmitter has been electronically calibrated at the factory before shipment. You will need to perform a wet calibration to compensate for electrode variations.

Wet calibration compares the output of the transmitter against the conductivity value of a test solution.

Wet Calibration should be performed while the 8800 Conductivity transmitter is being permanently installed. When done carefully, you can trim the transmitter accuracy to within $\pm 1\%$ of full scale.

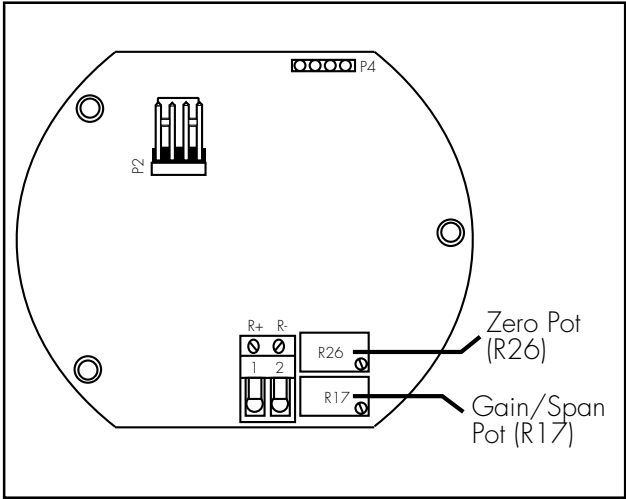

Figure 2
*Adjustment pots
and connectors*

Equipment Required

- Small screwdriver
- Power supply (10 to 30 VDC)
- Ammeter

2.2 Calibration Procedure

1. Connect power supply to transmitter input placing an ammeter in series with the input power, see Figure 3.

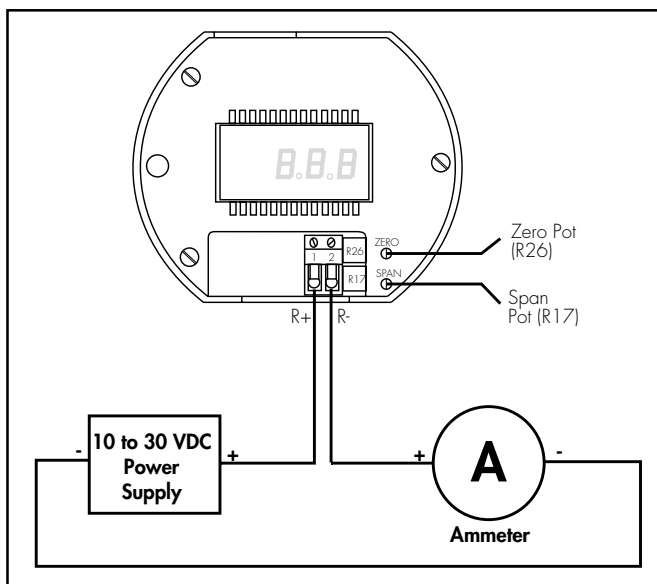

Figure 3

Transmitter Hook-up

NOTE:

The current output can be monitored in several ways (see Figure 8)

2. With the Conductivity electrode in the air (0 conductance) adjust the Zero pot (R26) for 4.00 mA.
3. Place the electrode into a solution of known conductance and adjust the Span pot (R17) for the corresponding mA value.

$$\text{mA} = [(\text{Known Cond.}/\text{Full Scale Cond.}) \cdot 16 \text{ mA}] + 4 \text{ mA}$$

4. Remove the sensor from solution and verify that the sensor reads 4.00 mA.
5. Repeat steps 2 through 4 as necessary.

2.3 Installing Optional Display Board

The addition of the display board option (p/n 3-8000.390) to the conductivity transmitter is done in the following manner.

1. Remove snap-on cover allowing access to the P4 connector.
2. Plug the four conductor ribbon cable into the P4 connector, see Figure 4.

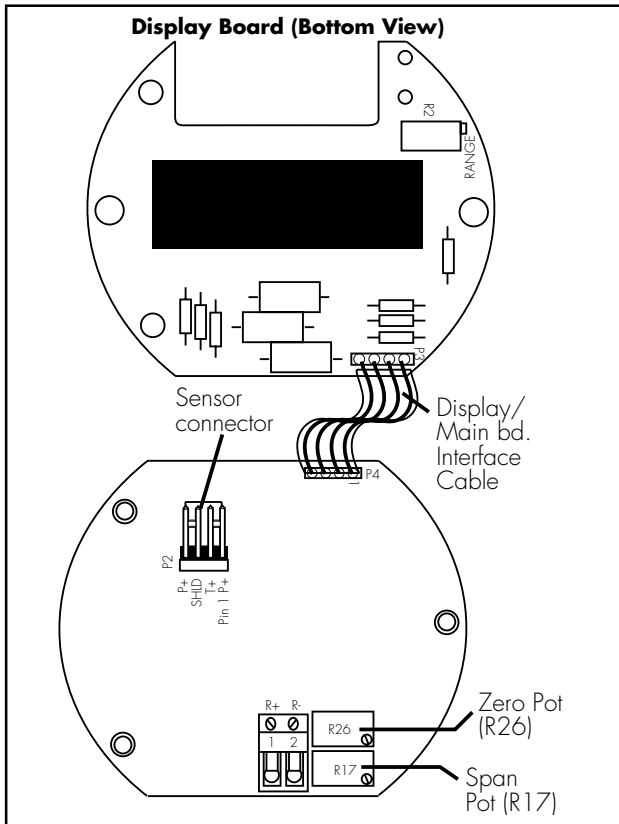

Figure 4

*Display Board
Installation Drawing
part no. 3-8000.390*

3. If necessary use a small blade (e.g Exacto knife) to remove any conformal coating from the standoff holes or calibration pot access holes.
4. Carefully snap the display board onto the three standoffs.
5. Re-calibrate the instrument as explained in section 2.2.

2.4 Display Board Range Adjustment

The display board displays from zero to one hundred percent of range. This PCB has a one-point calibration which may need to be done at installation.

1. Re-calibrate per section 2.2
2. Calculate percentage of full scale and adjust Range pot on display board so that the display shows the proper percent of Full Scale.

Model no.	Full Range
3-8800.103-1P	20 μ S
3-8800.103-2P	200 μ S
3-8800.103-3P	2,000 μ S
3-8800.103-4P	10,000 μ S

$$(\text{Solution value} \div \text{Full Range}) \cdot 100 = \text{Percentage}$$

Figure 5

Range Potentiometer Location



The display board draws approx. 200 μ A of current. When added, the transmitter requires recalibration.

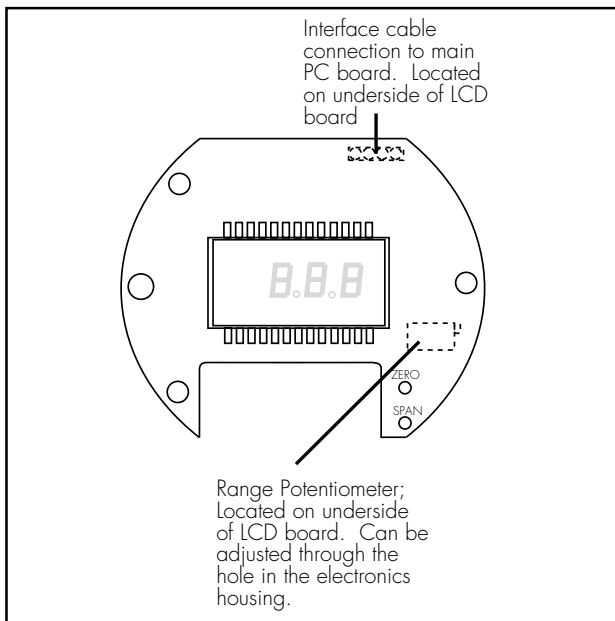

Chapter 3 Installation

3.1 General

This transmitter may be installed in harsh environmental locations. However, when possible the transmitter should be located so as to minimize the effects of temperature gradients and to avoid vibration and shock.

3.2 Positioning

In order to achieve good repeatable results care must be taken in the placement of the sensor. It is important that the sensor electrodes are fully immersed in the process fluid. Flow rates around the sensor must be limited so as not to produce air pockets which will affect the signal path through the fluid. We recommend that you do not mount completely upside-down as sediments may become trapped in the sensor and that you do not mount at the very top of the pipe because the pipe might not always be full.



The information provided on sensor positioning are recommendations only. The primary consideration is that the electrodes are in full contact with the process fluid. If sediments are present we recommend avoiding the 6 O'clock position.

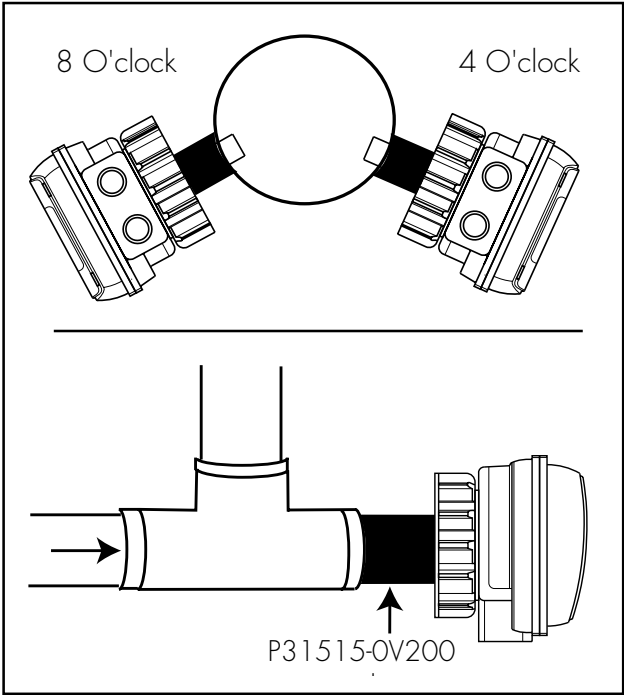

Figure 6

*In-line Sensor
Positioning Diagram*

3.3 In-Line Installations

The 8800 Conductivity transmitter sensor system is designed for installation into a pipe using standard +GF+ SIGNET fittings, (**up to 4 inch**) or the optional +GF+ SIGNET pipe adaptor fitting (p/n P31515-OV200). Refer to section 3.4 for additional information.



Caution: When installing saddle fittings, depressurize and drain pipe before drilling fitting hole.

+GF+ SIGNET plastic "glue-on" Tee Fitting

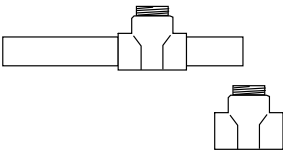

+GF+ SIGNET Plastic "glue-on" Saddle Fitting



3.4 In-line Fitting Options

These fittings provide the proper installation parameters that are critical to the calibration of the conductivity system.

Fitting Installation/Plastic Fittings

Tees:

- All tee fittings sold by +GF+ SIGNET are "glue-on" type except for the PVDF tees which are thermally fused. Be aware that PVC and CPVC tees require different types of primer and cement.
- Tee fittings are available for pipes from 0.5 to 4 inches in diameter.

Saddles:

- Plastic "glue-on" saddles are available for lines from 2 to 4 inches in diameter.
- 2 to 4 inch "glue-on" saddles require a 1-7/16 inch hole in the pipe. (O-ring not used with glue-on type)
- The hole must be completely deburred to be free of any projections.
- When assembling plastic saddles, the arrows on the wedges must match the direction of the arrows on the pipe saddle.

Misc:

+GF+ SIGNET also offers a pipe adaptor specifically designed for installing +GF+ SIGNET analytical sensors into in-line applications

(p/n P31515-0V200). This pipe adaptor can be installed in any standard 1-1/4 inch FNPT pipe fitting.

Fitting Installation/Metal Fittings

Welded fittings **MUST** be installed by a certified welder.

The plastic sensor insert in the Weldolet fitting MUST be removed during the welding process. When reinstalled, it is important that the insert be threaded to the proper height "H" dimension to ensure full insertion of the sensor electrodes, see page 10.

- 2 to 4 inch Weldolet fittings require a 1-7/16 inch hole in the pipe.
- The hole must be completely deburred to be free of any projections before installing the Weldolet fitting.

Pipe Tees: Metal Pipe Tees are available for 0.5 to 2 inch metal pipes. Materials include iron, carbon steel, stainless steel, and copper or bronze. All tees are threaded with NPT threads except for copper and bronze tees, which have solder or braze type fittings.

- Use thread sealant compound on fittings with threaded connections.

+GF+ SIGNET "weld-on" Weldolet Fitting



+GF+ SIGNET Metal Pipe Tee Fitting



Weldolet part number	"H" dimension inches
CS4W020	2.38
CS4W025	2.33
CS4W030	2.32
CS4W040	2.30
CR4W020	2.38
CR4W025	2.33
CR4W030	2.32
CR4W040	2.30

+GF+ SIGNET Weldolet Fitting

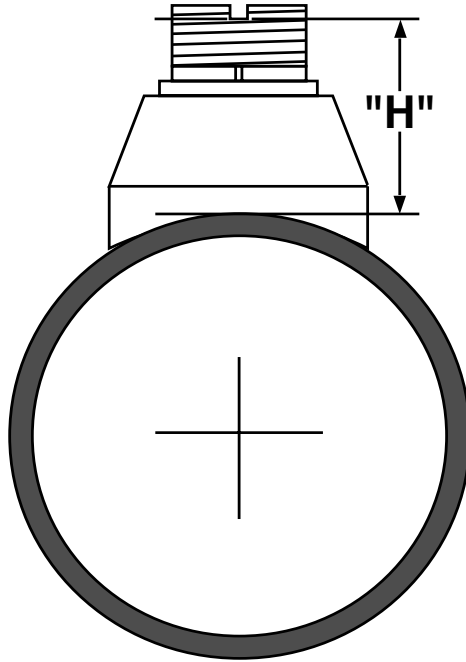

3.5 Submersible Installations

The 8800 Conductivity transmitter sensor system can be made submersible through the use of the submersible kit p/n 3-2700.391 and extension cable, p/n 3-8800.261-XX (-XX designates overall cable length from -01 to -12 ft., see Figure 1.

3.6 Electrical Installation

The transmitter has a 1/2 inch conduit opening for power/signal wiring, see Figure 7.

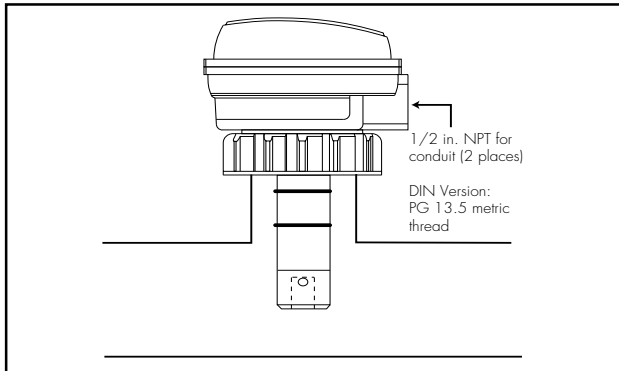
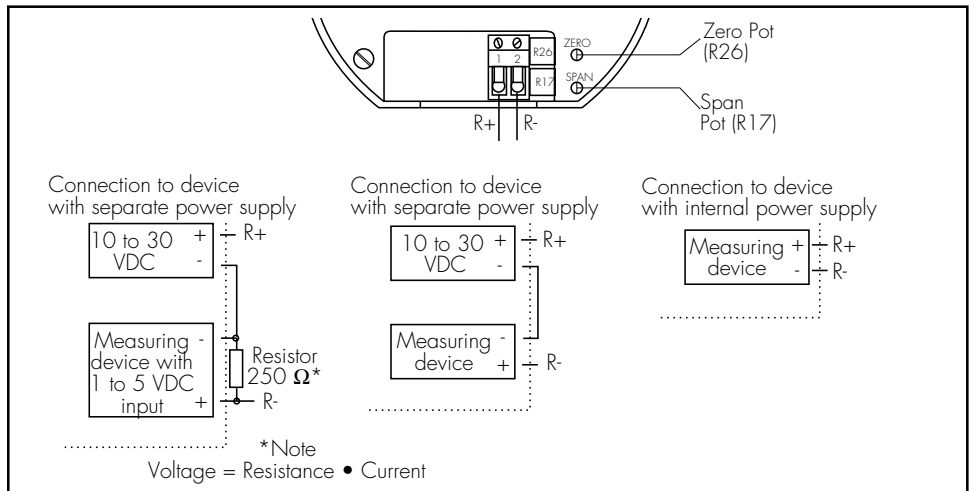

Figure 7
8800 Conductivity
Transmitter In-line
Installation

The sensor input connection is located on the lower PCB (below optional Display PCB). To access the connector, remove the housing cover followed by the electronics cover (snap on/off). The connector is now accessible between the Display PCB (if installed) and the Main PCB.

Signal wiring to the R+ and R- terminals need not be shielded, but 2-conductor shielded twisted-pair cable should be used for best results (Min. #22 AWG).

Figure 8
Transmitter Connection
Diagram



Signal wiring should not run in conduit or in open trays with HVAC wiring and should not be run near heavy electrical equipment. Leads should be color coded for polarity identification. The conduit connection on the transmitter housing should be sealed or plugged to avoid accumulation of moisture in the housing. If the conduit is not sealed, the transmitter should be mounted with the opening downward for draining.

Signal wiring may be ungrounded or grounded at any place in the signal loop. Power supply regulation is not critical. Make sure that the power supply source conforms to the requirements of the transmitter and that the current rating of the supply is not exceeded, particularly if more than one transmitter is connected to the supply in parallel.

NOTE:

This transmitter is designed to eliminate ground loops and other electrical interactions between system components even if several transmitters are powered by a common supply in parallel.

Make sure that electrical characteristics of the remote output device are compatible with the transmitter output: Total load resistance must not exceed 700 ohms using a 24 VDC power supply. Total load resistance is the sum of the individual resistances of all devices which are connected in series with the signal output lead.

Equation:

$$R_l = V_s - 10 / 0.02$$

where

R_l = Load Resistance in ohms

V_s = Supply Voltage

10 = Minimum operating voltage

0.02 = 20 mA (maximum current)

Chapter 4 Conductivity Sensor Maintenance

4.1 Maintenance Tips

The electrodes contact the solution and transfer a signal through the solution being measured. It is recommended that the electrodes maintain contact with fluid. If allowed to air dry, precipitates may form on the electrodes causing higher than normal readings and possibly contaminating the process fluid. If precipitates form, the electrodes may be cleaned by immersing the sensor in warm water and scrubbing the electrodes with a soft nylon brush.

It is important that the sensor is not exposed to oils which may coat the electrodes. This may seriously affect the readings.

In extreme cases it may be necessary to clean the sensor with alcohol to remove oils. We recommend using a cotton swab and brushing the electrode clean instead of dipping the entire sensor body in acetone.

In submersible applications the sensor should be located fully immersed and away from the presence of any bubbles.

In some instances it may be necessary to devise a periodic maintenance schedule to clean the electrodes and verify calibration.

4.2 Replacement Parts

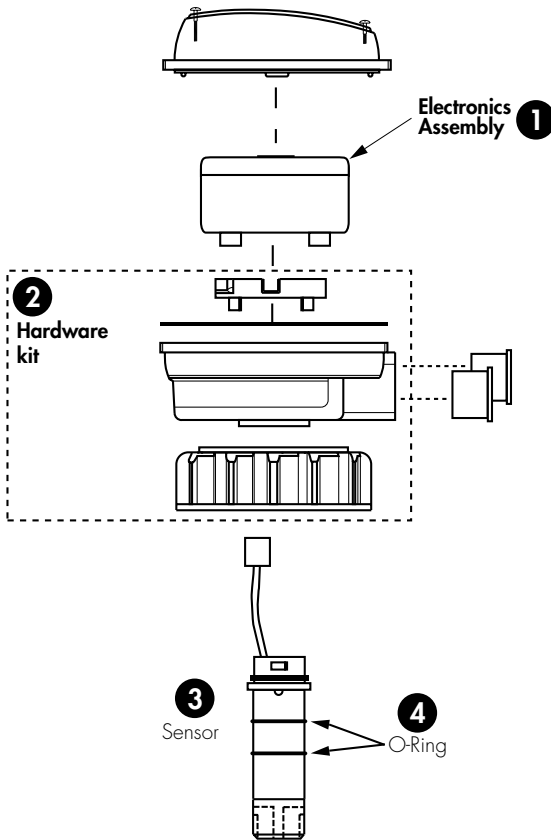

<u>Item</u>	<u>Part number</u>	<u>Description</u>
1.	3-8800.201-1 3-8800.201-2 3-8800.201-3 3-8800.201-4	Range, 0 to 20 μS Range, 0 to 200 μS Range, 0 to 2,000 μS Range, 0 to 10,000 μS
2.	3-8011 3-8011-D	Hardware kit with 1/2 in. NPT conduit ports Hardware kit with PG13.5 conduit ports
3.	3-8801.300-P 3-8800.300-P	Sensor, 0.05 cell Sensor, 2.0 cell
4.	1220-0021 1224-0021 1228-0021	O-ring, Viton® (2 required) O-ring, EPR (2 required) O-ring, Kalrez (2 required)

4.3 Troubleshooting Guide

Problem	Cause	Action
Display/output reads off scale	<ul style="list-style-type: none"> • Application range exceeds the electronics range. • Unit is not properly calibrated • Range pot misadjusted 	<ul style="list-style-type: none"> • Check unit model number, see Unpacking and Inspection section (opposite page #1) • Re-calibrate, see page 4 • Re-calibrate display, see page 5
Display/output reads zero (4 mA)	<ul style="list-style-type: none"> • Application range below the electronics range • Sensor not connected 	<ul style="list-style-type: none"> • Check unit model number, see Unpacking and Inspection section (opposite page #1) • Check sensor connection
Display is blank/ no current	<ul style="list-style-type: none"> • System power or ground OPEN 	<ul style="list-style-type: none"> • Check system wiring
Transmitter cannot be calibrated (insufficient Zero adjust)	<ul style="list-style-type: none"> • Gain pot set too high • Incorrect operating range • Excessive Quiescent current 	<ul style="list-style-type: none"> • Reduce Gain/Span pot adjust • Check unit model number, see Unpacking and Inspection section (opposite page #1) • Send for repair
Transmitter cannot be calibrated (insufficient Gain adjust)	<ul style="list-style-type: none"> • Incorrect operating range • Unit not calibrated • Output transistor damaged 	<ul style="list-style-type: none"> • Check unit model number, see Unpacking and Inspection section (opposite page #1) • Re-calibrate, see page 4 • Send for repair
Transmitter output changes erratically	<ul style="list-style-type: none"> • Air bubbles contacting sensor • Coated electrodes • Leaking submersion kit 	<ul style="list-style-type: none"> • Check installation • Clean sensor, see page 11 • Clean/replace cable install new seal

Specifications

Optional Display: 0 - 100%, 2-1/2 digit LCD
(factory installation recommended),
#3-8020.390

Loop power: 10 to 30 VDC

Loop impedance:

- 1Ω @ 10 VDC
- 100Ω @ 12 VDC
- 1000Ω @ 30 VDC

Electronics operating temp:

- -15 to 50 °C (5 to 122 °F)

Max sensor pressure/temperature:

- 7 bar @ 20 °C (100 psi @ 68 °F)
- 1.7 bar @ 90 °C (25 psi @ 194 °F)

Operating ranges:

- -1P 0 to 20 μ S 0.05 cell
- -2P 0 to 200 μ S 0.05 cell
- -3P 0 to 2,000 μ S 2.0 cell
- -4P 0 to 10,000 μ S 2.0 cell

Current output: 2-wire, 4 to 20 mA signal

Accuracy: $\pm 1\%$ of range

Relative Humidity: 0 to 95%, non-condensing

Enclosure materials:

- Electronics enclosure: Glass-filled PP, NEMA 4X/IP65
- Enclosure seal: Viton®
- Window: Polycarbonate

Wetted sensor materials:

- Sensor body: Glass-filled PP
- Electrodes: Titanium
- Sensor o-rings (2): Viton®
- Optional o-rings: EPR, #1224-0021
Kalrez, #1228-0021

Immunity: EN50082-1

Emissions: EN55011

Agency Approvals: CE

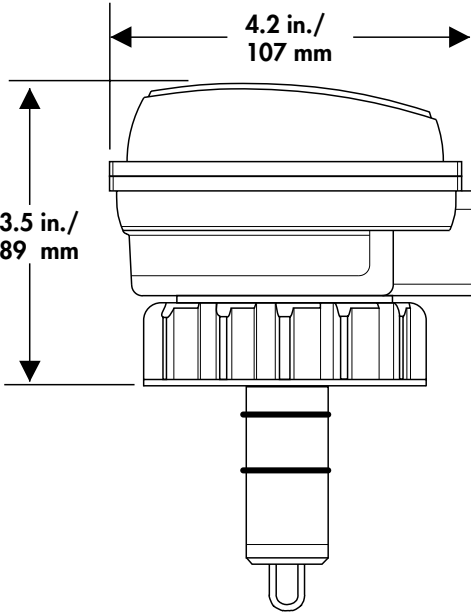

1/2 in. NPT
For Conduit
(2 places)
DIN Version:
PG 13.5
metric thread

Figure 9

8800 Conductivity Transmitter
Dimensional Views

0.05 Cell Constant
-1 (0 to 20 μS)
-2 (0 to 200 μS)

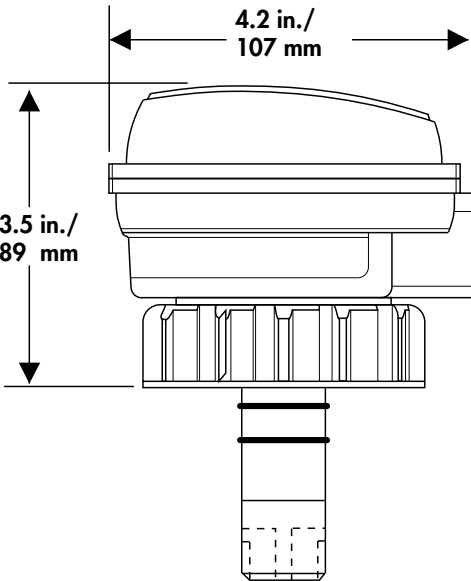

1/2 in. NPT
For Conduit
(2 places)
DIN Version:
PG 13.5
metric thread

2.0 Cell Constant
-3 (0 to 2,000 μS)
-4 (0 to 10,000 μS)

Warranty

Limited Two-Year Warranty

Signet Scientific Company warrants its instruments to be free from defects in material and workmanship under normal use for a period of two years from the date of purchase by the initial owner, or three years from date of manufacture, whichever comes first, as described in the following paragraphs.

This warranty does not cover defects caused by abuse or electrical damage. Signet Scientific Company will not cover under warranty any instruments damaged during shipment to the factory less case or if improperly packed. Repair attempts by anyone other than authorized service personnel will void the warranty. Proof of date of purchase will be required before warranty repairs can begin. Transducers and cables will not be covered after installation.

Parts which prove to be defective in the first year will be repaired or replaced free of charge including labor, shipped F.O.B. our factory or a designated service center (addresses furnished upon request).

Only non-moving parts, such as electrical components, which prove defective during the second year are warranted. Meter movements will not be covered. All units qualifying for warranty service after one year are subject to a service charge for replacement of non-moving parts.

Items returned for warranty repair must be shipped prepaid and insured. Warranty claims are processed on the condition that prompt notification of a defect is given to Signet Scientific Company within the warranty period.

Signet Scientific Company shall have the sole right to determine whether in fact a warranty situation exists.

Signet Scientific Company is continually making design changes and improvements that adapt to the original circuit configuration. These will be incorporated as required in older units on a minimal charge basis while under warranty.

Consequential Damages

Signet Scientific Company shall not be liable for special consequential damages of any nature with respect to any merchandise or service sold, rendered or delivered.

This warranty gives you specific legal rights and you may also have other rights which vary from state to state.

+GF+ SIGNET

Sales Offices:

- USA** George Fischer, Inc., 2882 Dow Avenue, Tustin, CA 92780/USA,
Tel. (714) 731-8800, Fax (714) 731-6201
- Switzerland** Georg Fischer Rohrleitungssysteme AG, P.O. Box 671, CH-8201 Schaffhausen/Switzerland,
Tel. 052/631 1111, Fax 052/631 2830
- Singapore** George Fischer Pte. Ltd., 15 Kaki Bukit Road 2, KB Warehouse Complex, Singapore 1441,
Tel. 65/747 0611, Fax 65/747 0577
- Japan** Kubota George Fischer, 2-47 Shikitsuhigashi, 1-Chome, Naniwa-Ku, Osaka, 556-91 Japan,
Tel. 816/648 2545, Fax 816/648 2565
- China** Georg Fischer Ltd., Rm 1503, Business Residence Bldg. of Asia Plaza,
2-3 Bldg. No. 5th Qu Anzhenxili, Chaoyang Qu, Beijing 100029, P.R. China,
Tel. 86/10 6443 0577, Fax 86/10 6443 0578
- Australia** George Fischer Pty. Ltd., Suite 3, 41 Stamford Road, Oakleigh, Victoria 3166, Australia,
Tel. 61/3 9568 0966, Fax 61/3 9568 0988

**Signet Scientific Company, 3401 Aerojet Avenue, El Monte, CA 91731-2882 U.S.A.,
Tel. (626) 571-2770, Fax (626) 573-2057**



PRINTED ON RECYCLED PAPER

Printed in U.S.A.

GEORGE FISCHER +GF+ Piping Systems

3-8800.090

B-11/97

© Signet Scientific Company 1992